

UTILITY **ELECTRIC** VEHICLE

DROPSIDE PICK UP



100% electric
0g of CO²/km



SPECIFICATIONS

- For the vehicle, refer to the chassis sheet
- Maximum payload on the deck from 500 up to 700 kg*
- Removable floorboard, rot-proof and nonskid
- 3 opening sides

OTHER VERSIONS

Canvas van



- Aluminium tubular structure
- 3 zips opening on rear side
- Rear view panel

Wide dropside pick up

1,25m
usable width



DROPSIDE PICK UP

OPTIONS



Cage



Net above cage



Canvas on cage

DIMENSIONS

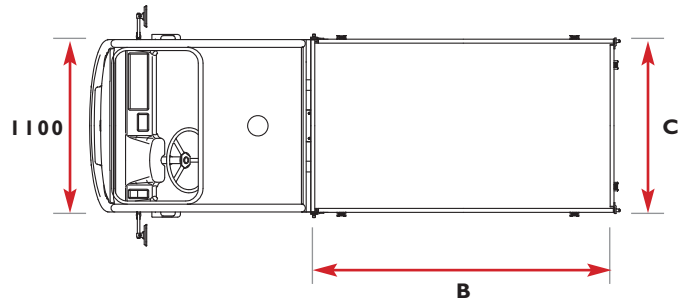
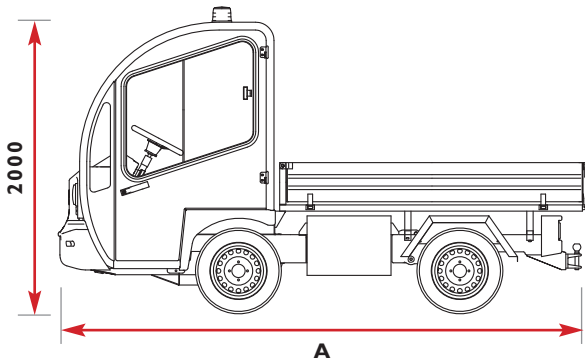

	Short version G3-S	Long version G3-L
	Vehicle Length (A) : 3 370 mm	Vehicle Length (A) : 3 870 mm
Standard version	deck Usable length (B) : 1 865 mm Usable width (C) : 1 035 mm Superficie : 1,93 m ²	deck Usable length (B) : 2 365 mm Usable width (C) : 1 035 mm Superficie : 2,45 m ²
Wide version	deck Usable length (B) : 1 865 mm Usable width (C) : 1 250 mm Superficie : 2,33 m ²	deck Usable length (B) : 2 365 mm Usable width (C) : 1 250 mm Superficie : 2,96 m ²