

UTILITY **ELECTRIC** VEHICLE

ISOTHERMAL BOX VAN



100% electric
0g of CO²/km



SPECIFICATIONS

- For the vehicle specifications, refer to the chassis sheet
- Maximum payload in the box from 350 up to 450 kg*
- Monted on tipper for battery access
- Isothermal box KLEGE-EUROPE, thickness of the sides 80mm
- One side opening left, right or rear
- Covered deck

OPTIONS AND ACCESSORIES

Cold unit



evaporator VO90 on mains
230-16A



The chiller only runs if the
vehicle is stopped and
plugged in on 230V sector



Double opening door

Stainless steel shelves :
double floor with 6
foldaway shelves



ISOTHERMAL BOX VAN

DIMENSIONS

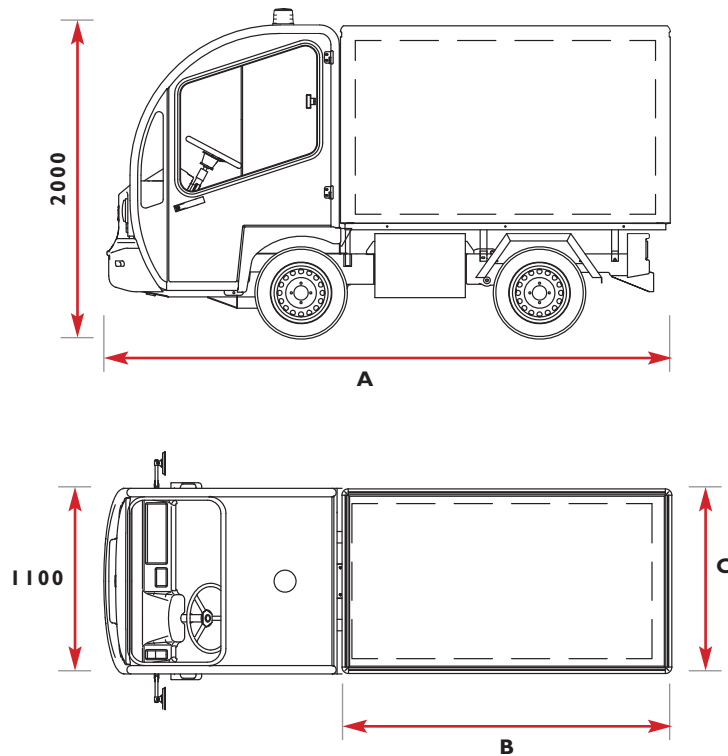

	Short version G3-S	Long version G3-L
	<p>Vehicle Usable length (A) : 3 345 mm</p>	<p>Vehicle Usable length (A) : 3 845 mm</p>
Wide version	<p>Isothermal box Usable length (B) : 1 775 mm Usable width (C) : 920 mm Capacity : 1,7 m³</p>	<p>Isothermal box Usable length (B) : 2 275 mm Usable width (C) : 920 mm Capacity : 2 m³</p>