

UTILITY **ELECTRIC** VEHICLE

BOX VAN

100% electric
0g of CO²/km



SPECIFICATIONS

- For the vehicle, refer to the chassis sheet
- Maximum payload on the deck from 500 up to 700 kg*
- Capacity from 2,2m³ to 3,4m³
- Rot-proof and nonskid floorboard
- Aluminium shutter with balance spring
- Shutter handle with keys

OPTIONS AND ACCESSORIES



Side ladder carrier



Remote central locking



Roof Rack



Interior light



2nd lateral shutter



Rear shutter



Mid height shelf



BOX VAN

OTHER VERSIONS



Combined deck / box van



Wide box van 1,25m cargo area width

DIMENSIONS

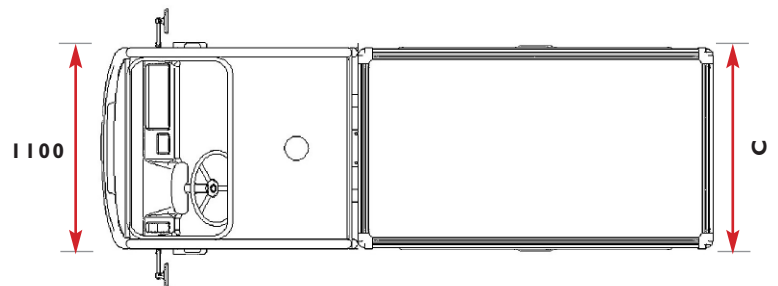
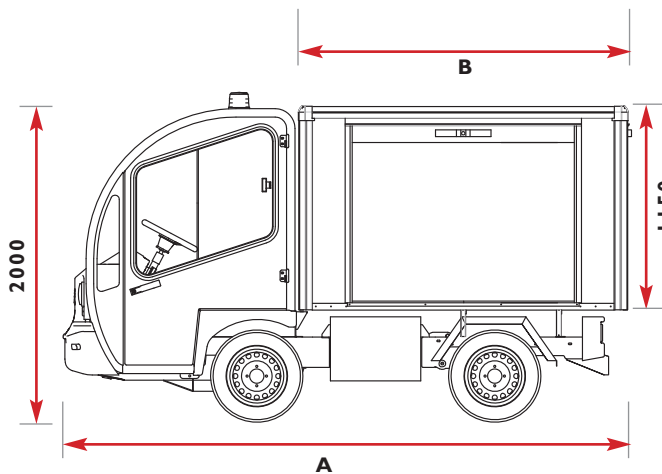

	Short version G3-S	Long version G3-L
	Vehicle Length (A) : 3 345 mm	Vehicle Length (A) : 3 845 mm
Standard Version	Box van Usable length (B) : 1 900 mm Usable width (C) : 1 020 mm Capacity : 2,2 m ³	Box van Usable length (B) : 2 400 mm Usable width (C) : 1 020 mm Capacity : 2,8 m ³
Wide version	Box van Usable length (B) : 1 900 mm Usable width (C) : 1 250 mm Capacity : 2,8 m ³	Box van Usable length (B) : 2 400 mm Usable width (C) : 1 250 mm Capacity : 3,4 m ³