

## UTILITY **ELECTRIC** VEHICLE **CHASSIS**



### EQUIPMENTS

- Cabin with windscreen wiper, 2 side mirrors and 2 sun visors and flashing roof beacon
- Digital display screen on dashboard including the following information:
  - Hourmeter and clock
  - Speedometer
  - Total and partial mileage
  - Battery water level alarm
  - Battery discharge level
  - Service frequency
- Controls:
  - Forward / Reverse speed indicator
  - Hazard lights
  - Buzzer and Wiper

- Fast / slow speed
- Bucket seats
- Doors with sliding windows
- Electric blower (optional)
- Electric defrosting windscreen (optional)
- Webasto gasoline heater (optional)
- Battery central water filling with water level sensor
- Storage compartments (long version)



## CHASSIS

### PERFORMANCES

Vehicle empty weight	925 kg
Maximum payload on the deck	from 500 to 700 kg <small>(according to the battery)</small>
Maximum vehicle weight incl. passengers	1710 kg
Maximum towing capacity	3 tons <small>(250 kg allowed on the road)</small>
Seats	2
Maximum speed	up to 40 km/h
Maximum slope (empty)	30%
Maximum slope (loaded)	18%
Noise at 25 km/h	62 dB

### LIGHTS & INDICATORS

- Headlights
- Winkers
- Stop and hazard lights
- Reverse light
- Reverse warning buzzer
- Horn
- Flashing roof beacon
- Forward motion buzzer (optional)
- Fog light

### SAFETY

- 3 points seat belts
- Parking brake with safety system
- Emergency stop
- Driver seat safety sensor
- Electric brake with energy recovery
- Road legal

### MANOEUVRABILITY

Turning radius : 3 m  
(4m for the long version)  
Ground clearance : 26 cm  
Overall width : 1,10m

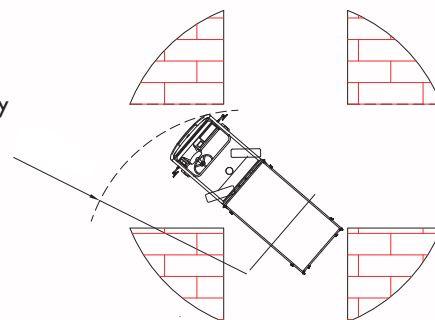

### DIMENSIONS

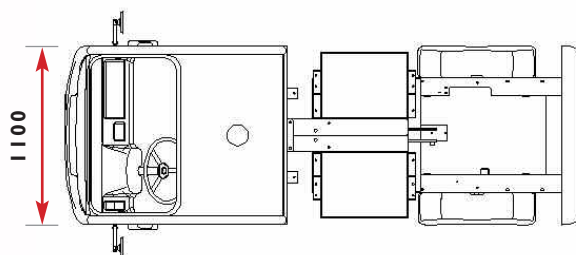
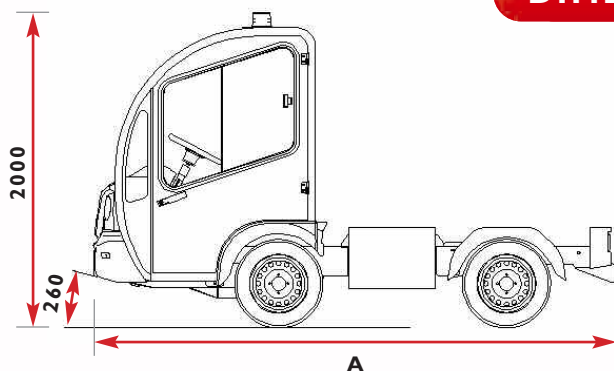

### DIMENSIONS

	Short version	Long version
Overall length	3 220 mm	3 720 mm
Overall width (excluding mirrors)	1 100 mm	1 100 mm
Height (incl. flashing roof beacon)	2 000 mm	2 000 mm
Ground clearance	260 mm	260 mm
Turning radius	3 000 mm	4 000 mm
Wheel base	1 410 mm	1 910 mm

## CHASSIS

### MECHANICAL SPECIFICATIONS

Front brakes	Drum hydraulic 230mm diameter
Rear brakes	Drum hydraulic 160mm diameter
Front suspension	Double triangle with helicoidal springs + shock absorbers
Rear suspension	Leaf springs in fiberglass + shock absorbers
Transmission	Rigid axle with 1:15.7 reduction + differential
Steering	Rack
Tyres	155/R13C M+S

### ELECTRICAL SPECIFICATIONS

Motor	AC, 5.4 kW at 2940 rpm - instantaneous output : 12.2 kW
Speed controller	Curtis 48V, 350A
Battery capacity	180Ah, 195 Ah, 240 Ah, 320 Ah, 400 Ah
Battery charger	Electronic high frequency, 48V-30A or 48V-50A
Consumption	2800W or 3000W
Charging time	8 to 10 hours

## OPTIONS

### Cabin



Without doors with arm rests



Wider windows



Interior panoramic rear-view mirror



Radio CD player



Industry seats



2 kg dry powder fire extinguisher

### Vehicle



Front bull bar



Men at work! triangular Led sign (AK5) on cab



Rear lights protective grill



Kit of reflective bands



Towing hook 50 mm with plug



Tyres : Low pressure turf tyres 23x8,5x12



External plug P17



Forward motion buzzer

Anti puncture treatment

### Defrosting system

Electric defrosting windscreen



Webasto gasoline heater

Electric blower

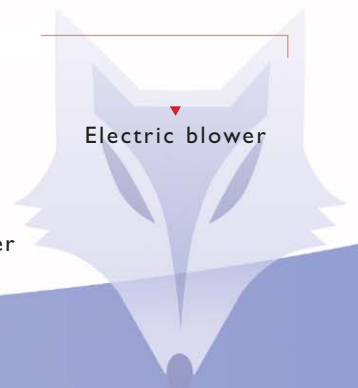

## CHASSIS

## BATTERIES



### TECHNICALS CHARACTERISTICS

Making	Open Lead Semi-traction Monobloc	Open Lead 2V traction cell	Open Lead 2V traction cell	Open Lead 2V traction cell
	Eight 6V cells	Twenty four 2V cells	Twenty four 2V cells	Twenty four 2V cells
<b>Capacity (5h)</b>	<b>195 A.h</b>	<b>180 A.h</b>	<b>240 A.h</b>	<b>320 A.h</b>
Warranty	2 years or 800 cycles	4 years or 1500 cycles	4 years or 1500 cycles	4 years or 1500 cycles
<b>Range <sup>(1)</sup></b>	<b>60 km</b>	<b>60 km</b>	<b>80 km</b>	<b>100 km</b>
Weight	256 kg	280 kg	372 kg	492 kg
<b>Payload on deck</b>	<b>700 kg</b>	<b>700 kg</b>	<b>600 kg</b>	<b>500 kg</b>

<sup>(1)</sup> The actual autonomy depends on the use of the vehicle – the payload, uneven roads (hills), number of start-ups, and the distance covered. Tests could be necessary to specify real needs.

<b>Charge</b>	The G3 can be charged on any 16A-230V standard plug. The high frequency charger is on board and automatically switches off after an equalization phase.
<b>Battery protection</b>	<ul style="list-style-type: none"> <li>• Battery discharge indicator on dashboard.</li> <li>• Battery protection : at 80% discharge of the capacity, the vehicle switches to slow speed, all electrical devices are switched off.</li> <li>• Low water indicator: in case of low water level, if no water is added within 2 days, the vehicle switches to slow speed until the batteries are refilled.</li> <li>• Water refill every 10 cycles.</li> </ul>

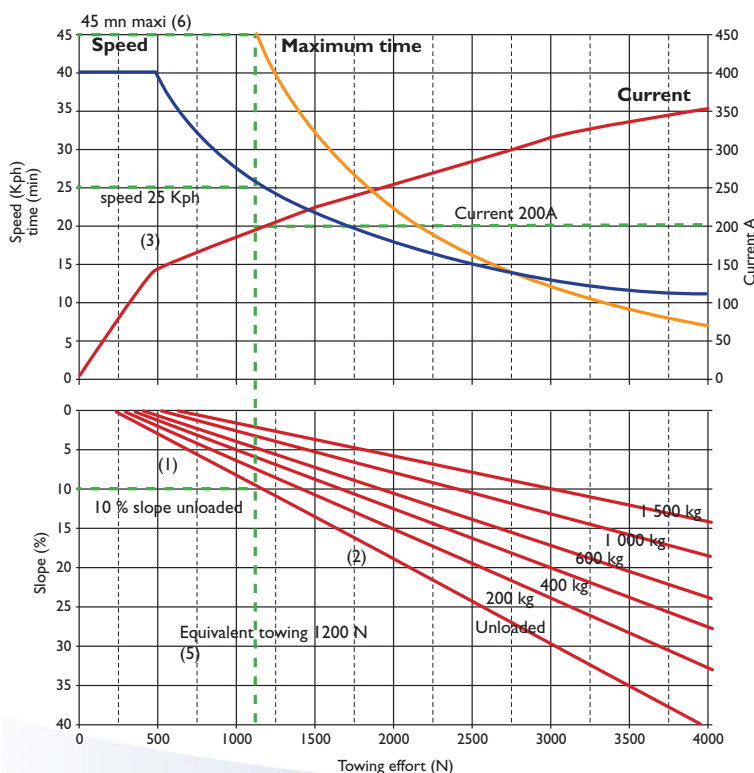

## MAXIMUM CAPACITIES

### EXAMPLE

On a 10% slope (1), with no load (2), we can drive at 25 kph (3) for a consumption of 200 A (4) and a equivalent towing effort of 1200 N (5) during 45 min maximum (6)